



**FEDERATION INTERNATIONALE DE SKI
INTERNATIONAL SKI FEDERATION
INTERNATIONALER SKI VERBAND**

**SPECIFICATIONS FOR
COMPETITION EQUIPMENT AND
COMMERICAL MARKINGS**

**Edition 2008
(valid as from the season 2008/09)**



INTERNATIONAL SKI FEDERATION
FEDERATION INTERNATIONALE DE SKI
INTERNATIONALER SKI VERBAND

Blochstrasse 2; CH- 3653 Oberhofen / Thunersee; Switzerland

Telephone: +41 (33) 244 61 61
Fax: +41 (33) 244 61 71
E-mail: richter@fisski.com
Website: www.fis-ski.com

Oberhofen, July 2008/GR

TABLE OF CONTENTS

A.	Definition	1
1.	Competition equipment	1
1.1	Competition implements	1
1.2	Additional equipment (accessories)	1
1.3	Auxiliary equipment	1
2.	Commercial Marking on Equipment	1
B.	Alpine Competition Equipment	1
1.	Alpine racing ski	2
1.1	Definition.....	2
1.2	Restrictions	2
1.2.1	Geometric features	2
1.2.1.1	Ski length.....	2
1.2.1.2	Profile width	3
1.2.1.3	Radius	3
1.2.1.4	Overall height of sectional view	4
1.2.1.5	Camber	4
1.2.1.6	Contour, length and height of shovel	4
1.2.1.7	Contour of tail	4
1.2.1.8	Running surface.....	4
1.2.1.9	Running Groove.....	4
1.2.2	Flexibility	4
1.2.3	Mass	4
1.2.4	Construction.....	4
1.2.4.1	Type.....	4
1.2.4.2	Ski components	4
1.2.5	Durability.....	4
1.2.6	Additional equipment	4
1.2.6.1	No additional equipment is permitted which	4
2.	Safety bindings	5
2.1	Anti-vibration plates	5
2.1.1	Width of ski surface	5
2.1.2	Maximum height	5
2.2	Ski stoppers	5
3.	Ski boots	5
3.2	Thickness of ski boot soles	5
4.	Ski poles	6
5.	Racing suits	6
5.1	Examination of materials, suits	6
6.	Crash helmets	6

7.	Ski goggles	7
8.	Ski gloves	7
9.	Back protectors	7
9.1	Definition.....	7
9.2	Specifications.....	7
9.3	Specifications for children	7
C.	Nordic Competition Equipment	7
1.	Cross-Country racing skis	7
1.1	Definition.....	7
1.2	Restrictions	8
1.2.1	Geometric features	8
1.2.1.1	Ski length.....	8
1.2.1.2	Ski width	8
1.2.1.3	Tip.....	8
1.2.1.4	Tail.....	8
1.2.1.5	Overall height of sectional view	8
1.2.1.6	Same construction	8
1.2.2	Flexibility.....	8
1.2.3	Mass	8
1.2.4	Construction.....	8
1.2.4.1	Type of construction	8
1.2.4.2	Ski components	8
1.2.4.2.1	Running surface.....	8
1.2.4.2.2	Top surface.....	8
1.2.4.2.3	Edges	9
1.2.5	Durability.....	9
1.2.6	Additional equipment	9
1.2.6.1	No additional equipment is permitted which	9
2.	Cross-Country racing bindings	9
3.	Cross-Country racing boots	9
4.	Cross-Country racing poles	9
4.1	Definition.....	9
4.2	General rules	9
4.2.1	Poles of equal length	9
4.2.2	Pole length.....	9
4.2.3	Constant length.....	9
4.2.4	Foreign energy.....	9
4.2.5	Weight	10
4.2.6	Construction.....	10
4.3	Technical Specifications	10
4.3.1	Grip.....	10
4.3.2	Straps	10
4.3.3	Shaft	10
4.3.4	Baskets.....	10

4.3.5	Tip.....	10
D.	Nordic Competition Equipment	10
1.	Jumping skis.....	10
1.1	Definition.....	10
1.2	Restrictions	10
1.2.1	Geometric features	10
1.2.1.1	Ski length.....	10
1.2.1.2	Profile width (see enclosure).....	11
1.2.1.3	Contour, length and height of shovel	11
1.2.1.4	Contour of tail	11
1.2.1.5	Running surface.....	11
1.2.2	Shape and Flexibility.....	11
1.2.3	Mass	11
1.2.4	Construction.....	11
1.2.4.1	Ski components	11
1.2.5	Durability.....	12
1.2.6	Additional equipment	12
1.2.6.1	No additional equipment is permitted which	12
1.2.6.2	Additional weights.....	12
2.	Jumping ski bindings.....	12
2.1	Binding wedges	12
2.3	Mounting of the bindings.....	12
3.	Ski-Jumping boots	12
4.	Ski-Jumping suits.....	12
4.1	Material, Fabric	14
4.2	Air permeability of the suit material.....	15
4.3	Underwear	16
4.4	Examination of materials, suits	16
5.	Crash helmets	16
6.	Ski goggles.....	16
7.	Ski gloves	16
E.	Freestyle competition Equipment	16
1.	Definition	16
	Competition equipment.....	16
1.1	Competition implements	17
1.2	Additional equipment (accessories)	17
1.3	Auxiliary equipment	17
2.	Commercial Markings on Equipment.....	17
2.1.	Freestyle Competition Equipment.....	17

2.2	Freestyle skis.....	17
2.2.1	Definition.....	17
2.2.2	Criteria.....	17
2.2.3	Geometric features.....	17
2.2.4	Ski length.....	17
2.2.5	Profile width.....	18
2.2.6	Radius.....	18
2.2.7	Overall height of sectional view.....	18
2.2.8	Camber.....	18
2.2.9	Contour, length and height of shovel.....	18
2.2.10	Contour of tail.....	18
2.2.11	Running surface.....	18
2.2.12	Running Groove.....	18
2.2.13	Flexibility.....	18
2.2.14	Mass.....	18
2.3	Construction.....	18
2.3.1	Type.....	18
2.3.2	Ski components.....	18
2.3.4	Durability.....	18
3.	Additional equipment.....	19
3.1	Safety bindings.....	19
3.2	Anti-vibration plates.....	19
3.3	Width of ski surface.....	19
3.4	Maximum height.....	19
3.5	Ski stoppers.....	19
4.	Ski boots.....	19
5.	Ski poles.....	20
6.	Competition suits.....	20
6.1	Ski Cross.....	20
6.2	Moguls.....	20
6.3	Aerials.....	20
6.4	Halfpipe.....	20
6.5	Helmets.....	20
7.	Ski goggles.....	20
8.	Ski gloves.....	20
9.	Back protectors.....	21
9.1	Definition.....	21
F.	Starting Bibs.....	21
1.	FIS Specifications for Alpine starting bibs.....	21
1.1	Advertising.....	21
1.2	Numbers.....	21

1.3	Assignment.....	21
1.4	Fabric, Material.....	21
1.5	Elasticity (stretch)	21
1.6	Seams, Sewing.....	21
2.	FIS Specifications for Cross-Country starting bibs.....	22
2.1	Advertising	22
2.2	Numbers	22
2.3	Assignment.....	22
2.4	Fabric, material.....	22
2.5	Elasticity (stretch)	22
3.	FIS Specifications for Ski-Jumping starting bibs	22
3.1	Advertising	22
3.2	Numbers	22
3.3	Assignment.....	22
3.4	Fabric, material.....	22
3.5	Elasticity (stretch)	22
	Procedures for Acceptance of Innovations in Competition Equipment	23
1.	Eligible applicants	23
2.	Items for application.....	23
3.	Prototype, samples.....	23
4.	Decisions of the Committee for Competition Equipment.....	23
5.	FIS Council	24
	Commercial Markings on Equipment.....	35
1.	General Principles	35
2.	Actual specifications	35
2.1	Skis, boots, bindings, ski poles, arm and leg protection, etc.....	35
2.2	Gloves	35
2.3	Goggles	35
2.4	Clothing	36
2.5	Helmets and Headgear.....	36
2.6	Other sponsors	37
2.7	Accessories	37
II.	By-laws for commercial markings and for advertising.....	38
A.	Commercial markings	38
A. 3	Measuring.....	38
B.	Advertising with athletes	38
B. 3	Not allowed in advertising with athletes:.....	38
C.	The above rules also apply in connection with press information or PR activities.	38

Specifications for Competition Ski Equipment

A. Definition

1. Competition equipment

The term „competition equipment“ embraces all items of equipment used by the athletes in competition skiing, including clothing and implements that serve a technical function. The entire competition equipment forms a functional unit. In this connection the following points must be observed:

- a) the principal of safety
- b) the principal of fairness

1.1 Competition implements

Competition implements refer to those parts of the equipment which fulfil essential functions for the competition and which are separable from the competition.

Examples: skis, bindings, boots, poles, clothing, helmets, ski goggles.

1.2 Additional equipment (accessories)

Additional equipment (accessories) to competition equipment are those components or implements which have an influence on the technical function of the competition equipment and which are attached directly to the equipment by means of recognised fastenings. Accessories do not perform essential functions for the competitions.

Example: parablacks, plastic tip covers, additional weights, back protectors.

1.3 Auxiliary equipment

Auxiliary equipment refers to those components of the competition equipment which do not fulfil an essential function, and which do not fall under the heading of additional equipment

Example: measuring instruments.

2. Commercial Marking on Equipment

Specifications on pages 35 to 38

B. Alpine Competition Equipment Downhill, Slalom, Giant Slalom, Super G

Only measurements which are carried out by the appointed FIS equipment measurement experts using the official FIS measurement tools are valid.

The results of measurements carried out at the time are valid and final, irrespective of previous measurements.

1. **Alpine racing ski**

Extension of the tolerance for skis and boots at FIS and ENL levels (new rules were strictly applied for World Cup level from the 2007/08 and for Continental Cup from 2008/09 season).

1.1 **Definition**

Skis, predominantly for Downhill, Slalom, Giant Slalom and Super G racing through gravitational force on suitable terrain. To guarantee the skier optimum use of the sides of the skis for steering, the edges of the running surface are made mainly of hard sealed materials.

1.2 **Restrictions**

1.2.1 *Geometric features*

For MAS racers the following specifications in regard to ski length and radius (except Super-G) are recommendations. The Specifications for Super-G skis are compulsory also for MAS racers.

1.2.1.1 *Ski length*

Minimum length "developed" length (unwound length) in accordance with ISO Norm including a measurement tolerance of +/- 1 cm. The ski length has to be marked on the ski.

Downhill

Ladies WC/WSC/OWG/COC:	210 cm
Ladies FIS:	210 cm / -5 cm tolerance
Men WC/WSC/OWG/COC:	215 cm
Men FIS:	215 cm / -5 cm tolerance

Super-G

Ladies WC/WSC/OWG/COC:	200 cm
Ladies FIS:	200 cm / -5 cm tolerance
Ladies MAS (Giant Slalom Skis allowed):	180 cm / without tolerance
Men WC/WSC/OWG/COC:	205 cm
Men FIS:	205 cm / -5 cm tolerance
Men MAS (Giant Slalom Skis allowed):	185 cm / without tolerance
Children II:	175 cm

Giant Slalom

Ladies WC/WSC/OWG/COC:	180 cm
Ladies FIS:	180 cm / -5 cm tolerance
Ladies MAS:	180 cm / -5 cm tolerance
Men WC/WSC/OWG/COC:	185 cm
Men FIS:	185 cm / -5 cm tolerance
Men MAS:	185 cm / -5 cm tolerance

Slalom

Ladies (all categories):	155 cm
Men:	165 cm
Men Junior I at FIS and ENL races:	165 cm / -10 cm tolerance
Children I & II:	130 cm

MAS:

No length restriction for Ladies over 60 years and Men over 70 years.

Precision for the length of Slalom Skis:

When a ski tip different from the main ski part is used, the measurement will only be taken into account to the extent it covers a surface corresponding to the natural shape of the ski.

The manufacturer has to mark the tip showing the limit of the natural shape and therefore allow an easy measurement.

For the avoidance of doubt, specific designs of the ski tips as part of the main body of the skis are allowed.

Recommendation for children younger than 11 years

For children younger than 11 years: Use only one pair of skis in all events if the ski length is shorter than 130 cm.

1.2.1.2 *Profile width*

Minimum width of the running surface at binding without any tolerance.

WC/WSC/OWG/COC

DH Ladies' & Men:	minimum 67 mm
SG Ladies' & Men:	minimum 65 mm
GS Ladies' & Men:	minimum 65 mm
SL Ladies' & Men:	minimum 63 mm

FIS and ENL

Ladies & Men	minimum 60 mm
--------------	---------------

1.2.1.3 *Radius*

The radius has to be marked on the ski.

Downhill

Ladies & Men:	minimum 45 m
---------------	--------------

Radius measurement for DH skis with a preparation tolerance of -1 m.

Super-G

Ladies & Men:	minimum 33 m
Children II:	minimum 27 m

Giant Slalom

WC/WSC/OWG/COC

Ladies:	minimum 23 m
Men:	minimum 27 m

FIS/ENL

Ladies & Men	minimum 21 m
Children II:	minimum 17 m
Children I:	minimum 14 m

- 1.2.1.4 *Overall height of sectional view*
No limitations.
- 1.2.1.5 *Camber*
No limitations.
- 1.2.1.6 *Contour, length and height of shovel*
Slalom and Giant Slalom: minimum height per ski: 50 mm
Downhill and Super G: minimum height per ski: 30 mm
- 1.2.1.7 *Contour of tail*
Maximum height: 10 mm.
- 1.2.1.8 *Running surface*
No limitations
- 1.2.1.9 *Running Groove*
No limitations
- 1.2.2 *Flexibility*
No limitations with regard to the rigidity in all grades of flex.
- 1.2.3 *Mass*
No limitation with regard to weight and distribution of mass.
- 1.2.4 *Construction*
- 1.2.4.1 *Type*
No limitation with regard to composite structure.
- 1.2.4.2 *Ski components*
Running surface: no limitations with regard to material and dimensions.
Torsion box: no limitations with regard to material and dimensions.
Edges: no limitations with regard to material and dimensions.
Top surface: no limitations with regard to material and dimensions.
Core: no limitations with regard to material and dimensions.
- 1.2.5 *Durability*
With regard to the mounting of bindings, national norms and at least the „Ö-Norm 4030“, that is the equivalent of DIN- and ISO-norms, must be fulfilled.
- 1.2.6 *Additional equipment*
- 1.2.6.1 *No additional equipment is permitted which*
- a) makes use of foreign energy (e.g. heaters, chemical energy accumulators, electric batteries, mechanical aids, etc.)
 - b) causes or intends to cause changes in the outer conditions of the competition to the disadvantage of fellow competitors (e.g. changes to piste or snow)
 - c) increase the risk for the users or other persons, when used for the purpose it was intended for.

4. Ski poles

The ski pole is a sports article whose function should aid the skier, facilitate balance and, if necessary, enable stopping. The national and international guidelines and norms establish the minimum requirements for ski pole tips, grips, shaft, baskets, straps, length, etc. Due to risk of injury, metal baskets are not permitted.

5. Racing suits

Competition suits and any clothing or protectors worn beneath, such as underwear, etc., may not be plastified or treated by any chemical means (gaseous, liquid or solid) and must have a minimum permeability of 30 litres per m²/sec. Seams may only exist in order to join the portions of the suit. Outer tucks and darts are not allowed. The suits must be equally porous in all parts, both from the outside in and from the inside out. Minimum air permeability is established as follows:

The unstretched fabric must show a medium air permeability of a minimum of 30 litres per m²/sec under 10 mm of water pressure.

For Giant Slalom and Super G suits' shoulder and arm sections, as well as knees and shins may be specially protected. For Slalom suits shoulder and arm sections as well as legs may be specially protected.

The competitors are allowed to protect all parts of the body with so-called protectors. The anatomic body shape may not be changed. No plastified surfaces.

Protection that fulfils the 30 litre rule can be worn under a racing suit.

In Super-G and Giant Slalom (but not Downhill) in the areas shoulder and arm sections, protection that does not pass the 30 litre rule does not have to be integrated into the competition suit.

5.1 Examination of materials, suits

The guidelines for minimum air permeability established by the Control Procedures/Equipment Working Groups in collaboration with the Federal Institute for Materials Control are valid. Multi-layered materials are accordingly permitted for alpine racing suits, as long as they conform to the air permeability requirements in question.

6. Crash helmets

The use of crash helmets is compulsory for all events.

Only helmets are permitted whose shell and padding cover the head and ears. The National Ski Associations are advised to provide their teams only with crash helmets which satisfy the minimum requirements for the respective event and which have been certified by recognised institutes.

Helmets with spoilers or edges that stick out are not permitted.

Certain helmets must show a smooth top surface for safety reasons.

Helmets used in FIS Snowsports shall be specifically designed and manufactured for the respective discipline and shall bear a CE mark and conform to recognized and appropriate standards such as CEE 1077 or US 2040, ASTM F2040, SNELL S98 or RS 98, etc.

Soft ear protections are only allowed for SL events.

7. Ski goggles

Ski goggles are devices protecting the eyes against weather and rays with optically correct lenses. Their aim is to guarantee good, contrast-free visibility in all weather conditions. The use of ski goggles is recommended. Reshaping the ski goggles in order to attain more aerodynamic features is not allowed.

8. Ski gloves

Gloves offer protective covering against weather and external forces. The wearing of gloves is urgently recommended. Reshaping the glove, the application of a plastic coating on the outer surface, or the use of skai (imitation leather) with the aim of attaining more aerodynamic features, are not allowed. The glove must not reach beyond the elbow. Protective padding along the entire length of the glove is permitted. The use of protective guards in the form of shields, which are pulled over the glove, is permitted.

9. Back protectors

9.1 Definition

The back protector is an additional item of equipment, which protects the athlete's back against weather and external forces.

9.2 Specifications

The back protector must adapt to the anatomical bend of the athlete's spine and lay flat against the body. The top edge of the back protector has to be situated in the area of the spinal column and may not go above the 7th cervical vertebrae (C7). Fastening of the back protector may only take place with a stomach belt. The maximum thickness has to be in the middle part and may not exceed 45 mm; the thickness reduces at the edges of the back protector. All designs to improve aerodynamic properties are forbidden. The back protector may be worn exclusively under the competition suit.

9.3 Recommendation for specifications for children

Children under 11 years should use back protectors (also for CHI I and CHI II)

C. Nordic Competition Equipment

Cross-Country Skiing

1. Cross-Country racing skis

1.1 Definition

The cross-country racing ski is a type of ski, whose features guarantee the best possible application of the gliding techniques to master cross-country pistes (uphills, bumpy terrain, downhill). The basic features of this type of ski are defined in these rules.

1.2 Restrictions

1.2.1 Geometric features

1.2.1.1 Ski length

Minimum: height of skier minus 100 mm

1.2.1.2 Ski width

In the binding fixation area of the ski defined by ISO 9119 or Ö-Norm S4072

Minimum 40 mm

1.2.1.3 Tip

The minimal shovel curvature is 30 mm.

1.2.1.4 Tail

The tail must not rise more than 30 mm on the unweighted ski when laying on a flat surface.

1.2.1.5 Overall height of sectional view

Maximum 35 mm

Minimum 20 mm

1.2.1.6 Same construction

Both skis must be constructed in the same way, and must be the same length.

1.2.2 Flexibility

No restrictions with regard to the rigidity in all grades of flex.

1.2.3 Mass

Skis must weigh at least 750 g per pair. No limitations with regard to the distribution of mass.

1.2.4 Construction

1.2.4.1 Type of construction

No limitations.

1.2.4.2 Ski components

1.2.4.2.1 Running surface

The entire width of the running surface can be smooth or slightly grooved length-wise. With the exception of the running groove, however, the level must be constant in the entire length and width. Climbing aids in the form of scale patterns or step patterns are permitted. Models driven by means of foreign energy of any kind are not permitted.

1.2.4.2.2 Top surface

No limitations

1.2.4.2.3 *Edges*

The edges must not face up and outwards, making the running surface narrower than the top surface (no wedge shape).

1.2.5 *Durability*

No limitations

1.2.6 *Additional equipment*

1.2.6.1 No additional equipment is permitted which

- a) makes use of foreign energy (e.g. heaters, chemical energy accumulators, electric batteries, mechanical aids, etc.)
- b) causes or intends to cause changes in the outer conditions of the competition to the disadvantage of fellow competitors (e.g. changes to piste or snow)
- c) increases the risk of injury to users or other persons, when used for the purpose it was intended for.

2. **Cross-Country racing bindings**

No limitations with regard to material and make, subject to decisions 1.2.6 b) and c).

3. **Cross-Country racing boots**

No limitations with regard to material and make.

4. **Cross-Country racing poles**

4.1 **Definition**

The cross-country racing pole is a pole, whose features guarantee the best possible application of the gliding techniques to master cross-country pistes (uphills, bumpy terrain, downhills).

4.2 **General rules**

4.2.1 *Poles of equal length*

Two poles of equal length must be used in competition, with one pole held in each hand.

4.2.2 *Pole length*

The maximum pole length must not exceed the competitor's height, nor measure below the hips (measurements are taken by placing the tip of the pole on the ski in front of the binding).

4.2.3 *Constant length*

The pole must have a constant length. It may not, for example, possess a telescopic system.

4.2.4 *Foreign energy*

The pole must not create a foreign energy to favour push-off (e.g. springs or mechanical devices).

4.2.5 *Weight*

No limitations regarding the weight of the pole.

4.2.6 *Construction*

The poles may be constructed asymmetrically (e.g. there may be a difference between left- and right-hand poles).

4.3 **Technical Specifications**

4.3.1 *Grip*

The grip must be attached to the shaft. There are no limitations with regard to geometric features or material.

4.3.2 *Straps*

The straps must be joined to the grip or the shaft. They may be adjustable in length and width.

4.3.3 *Shaft*

There are no limitations with regard to material and make of the shaft or distribution of mass.

4.3.4 *Baskets*

Baskets with varying geometric features and materials are permitted to master various snow conditions. The baskets, however, must not change the condition of the track, so that other competitors suffer disadvantages.

4.3.5 *Tip*

Tips may be joined to the shaft at any angle. It is permitted to use one or more tips per pole. There are no limitations with regard to material.

D. Nordic Competition Equipment

Ski-Jumping

1. Jumping skis

1.1 Definition

Jumping Skis are manufactured especially for use on ski-jumping hills. Their construction is adapted to the requirements of ski-jumping.

1.2 Restrictions

1.2.1 Geometric features

1.2.1.1 Ski length

According to the body weight/height relationship (body weight / body height² in Kg/m² - see the measurement table in the enclosure).

However, the maximum ski length is 146 % of the total body height of the competitor.

Exception:

For Youth competitions, the maximum ski length is limited to 143 % from the body height only (no BMI formula will be applied)!

1.2.1.2 *Profile width (see enclosure)*

The curvature from A through B to C indicates the shape of the ski side cut. This curvature must be equal on both sides and symmetrical to the ski centre line. As a maximum the line connection from A to B, as well as B to C should appear as a straight line.

Minimum width of the running surface at the point of balances 95 mm, maximum width 105 mm.

The edges must form a 90° angle to the running surface and the top surface along the entire length of the ski.

Rounded top-to-bottom edges must never be more than 2 mm.

The difference between the above-mentioned measurement of the width of the ski tip and the ski tail may not exceed 5 mm.

1.2.1.3 *Contour, length and height of shovel*

The ski tip may be individually modified as long as it remains symmetric and centred to the middle part and that the minimum distance to the ground of 30 mm is observed.

1.2.1.4 *Contour of tail*

Maximum height 10 mm

1.2.1.5 *Running surface*

Running surface must be flat and may have a fine base structure in a longitudinal direction. With the exception of the grooves, the entire ski base cannot have any additional shapes. There can be one or more grooves; however the total of the measured surface area of all the grooves may not exceed 50% of the minimal width of the ski. The width of a single groove may not exceed 10 mm. The base must be of a polyethylene material.

1.2.2 *Shape and Flexibility*

Aerodynamic coverings on the tips, as well as fins in the form of stabilizers on all sides are not allowed. A design, which makes a desired aerodynamic flex possible during flight, is not allowed. Otherwise there are no limitations with regard to rigidity in all grades of flex. The top surface of the ski must be smooth and flat.

1.2.3 *Mass*

A single non-mounted ski must have a minimum weight conforming to its length (the weight in dkg results of the ski length in cm: e.g. 250 cm = 2,50 Kg, 262 cm = 2,62 Kg). Lead-weights used for balancing the centre of gravity are not considered (see 1.2.6.2).

1.2.4 *Construction*

1.2.4.1 *Ski components*

Torsion box: No limitations with regard to material and dimensions.

Edges: see 1.2.1.2.

1.2.5 Durability

The jumping ski must have screw retention strength of 1600 N in the area of the binding mounting.

1.2.6 Additional equipment

1.2.6.1 No additional equipment is permitted which

- a) makes use of foreign energy (e.g. heaters, chemical energy accumulators, electric batteries, mechanical aids, etc.).
- b) causes or intends to cause changes in the outer conditions of the competition to the disadvantage of fellow competitors (e.g. changes to piste or snow).
- c) increases the risk of injury to users or other persons, when used for the purpose it was intended for.

1.2.6.2 Additional weights

Additional weights for balancing the centre of gravity are permitted.

2. Jumping ski bindings

Additional devices creating foreign energy of any kind as an aid to take-off are forbidden.

The complete binding system must be mounted so, that the ski-jumping shoes are fixed to the skis symmetrically, parallel and centrally to the running direction. The outline of the heel wedge of the shoe sole in its normal production form may not protrude over the side-walls of the Jumping ski.

2.1 Binding wedges

Binding wedges are permitted to improve the in run position. The entire height of the boot sole and binding wedge must not exceed 70 mm.

2.3 Mounting of the bindings

The binding must be mounted in such a way that maximum 57% of the entire ski length is used as the front part. Measured from the ski tip (with shovel curvature) to the shoe cap (leather part). (The 57% will be rounded up or down to full centimetres).

3. Ski-Jumping boots

The shoe size and form must equal the foot size and form. Reshaping the boots in order to attain more aerodynamic features is not allowed. The boot sole may not exceed 45 mm.

4. Ski-Jumping suits

All portions of the ski jumping suit must be made of the same material (see 4.2) and must show the same air permeability from the outside in and from the inside out.

The suit must close by means of a zipper placed at the centre of the front, which reaches to the collar. The width of this zipper may not exceed 10 mm. During the jump the zipper must be completely closed. The design of the suit (seams) must conform to the image "Ski Jumping Suits" in the enclosure (page 33/34)

The maximum tolerance in the size of the suit is 6 cm to the body size at any part of the suit.

Exceptions are the anterior sleeve length where the maximum tolerance is 6 cm (8 cm for the ladies), to accommodate the fit of the suit over the boot, a maximum tolerance of 10 cm is given to the suit below the knee and the anterior crotch length, where no tolerance is permitted.

Additional restrictions

- Marking of the suit (for measuring and control) is allowed.
- The thickness of all parts of the suit must be the same.
- No additional chemical (gaseous, liquid or solid) or mechanical treatment of the material or suits is allowed.
- The collar of the Jumping suit may have a tolerance and not exceed 8 cm in regarding the measurement of the throat. The collar of the suit must be ended by a non elastic seam band. The collar of the suit must be placed no higher than the joint of the collar bones (see the illustration - mark X). The height difference between the front and the back of the collar may not exceed 5 cm (see the illustration - mark X1 and X2).
- Outer tucks and darts, folds and padding are not allowed.
- Only one fixed (non-adjustable) strap per leg is allowed for fixing the suit around the ski boot. The strap is of one continuous piece and without clips, buckles or other means of fastening multiple pieces of material. The fixation of either strap must be made at the hem of the suit (see the illustration - mark S).
- Length of the sleeve maximally to the wrist joint. The lower hem of the sleeve is cut evenly and has no integrated hole for fingers.
- All hems must be sown by a singular piece and the entire piece must have the same physical material characteristics.
- Standardized measuring control points:
 - Anterior arm length (see the illustration - mark AL) is measured from the intersection of the seams at the armpit, following the seam to the end of the sleeve. Measured length must be no greater than the length of the arm and no shorter than a maximum tolerance of 8 cm.
 - Anterior crotch length (see the illustration - mark SL) is measured from the intersection of the seams at the crotch of the suit (see the illustration - mark SX) following the anterior seam to the hem of the leg part of the suit.
Measured length of the suit must be no shorter than the measured length of the controlled crotch height.
- Number of parts of the material of which the suit consists is:
 - 2 for each sleeve including shoulder: front part of the sleeve (see the illustration - mark 3) and back part of the sleeve (see the illustration - mark 5). Each sleeve starts from the neck opening and extends over the shoulder to maximally the wrist joint. Starting from the armpit down the size of the panels must be equal front and back. The alignment of the posterior seam must be centered along the length of the sleeve and parallel to the torso seam. In addition, when the arm is extended from the torso, the anterior seam of the sleeve must be aligned with the torso seam.

- 5 for the torso (upper body above the waist seam): left and right front panels (see the illustration - mark 1), left and right side panels (see the illustration - mark 7). Each side panel must be a minimum of 10 cm in width and no greater than 15 cm in width.
- 2 for each leg (under the waist seam): the front leg panels (see the illustration - mark 2) and the back leg panels (see the illustration - mark 6). Starting from the crotch down, the size of the panels must be equal front and back. The alignment of the posterior and anterior seams is centered along the length of the leg. The front and back crotch seams must connect with the anterior leg seams at the lowest point of the crotch (see the illustration - mark SX).
- Zipper, elastics and strings for the attachments do not count as a separate part of the suit.
- The waist seam must be placed in relationship to the body within 10 cm above the hip bone (narrow part of the waist). The seam must go around the torso horizontally.
- The seam connecting the upper front and side panel must align vertically with the seam of the leg panels from the armpit to the posterior ankle bone, when the athlete is wearing it in an upright position.
- The bottom hem of the leg panels may be altered to accommodate the fixing of the binding at the heel of the boot.
- Seams may only exist in order to join the portions of the suit. Seams must be inside the suit. It is not allowed to edge-stitch (sew) the ends of the material; it is not allowed to join (sew) the maximum seam of 12 mm (material behind the seam to the edge). All seams must be straight or formed differently only to fit the form of the body. Any additional seams or transformation of the seams, any strings, rods, folds, tapes, etc., inside or outside the suit in order to attain greater volume or more aerodynamic features is not allowed (the same for the underwear).
- The enclosed suit illustrations are the determining bases for these written rules. Exception for Youth competitions: no limit for number of parts and cutting of the suits.

4.1 Material, Fabric

The structure of the surface of the material and the composition of the material for all parts of the suit must be the same. The only exceptions are different colours of the same material.

The thickness of the suit may not exceed 5.0 mm, nor be less than 4.0 mm.

Construction of the ski-jumping suit is a five-layer laminated fabric and consists of:

- outer fabric/ first layer
- foam
- elastic membrane
- foam
- lining fabric

The components are laminated together by either a hot-melt process or flame laminated, where 4 acts are necessary to laminate the fabric.

The controlled air permeability of 40 l/m²/sec. (FIS Rules) is reached by perforation and guarantees a constant value.

Outer fabric / first layer

The outer fabric for the ski jumper laminate is a bi-elastic warp-knit fabric, called Charmeuse (pattern notation). This material is produced on a 2-thread system warp knitting machine.

Material: 81 % Polyamid gloss dtex 44f12
19 % Elasthane (Lycra) dtex 44f1

Weight: 180/190 g/m² approx.

Elasticity: Length 150-160%
Width approx. 85-95%

Finishing:

The quality is dyed in a classical piece dyeing method (acid dyestuff). Beside the dyestuff and eventual dyeing assistant there is no use of other chemical stuff allowed, which would change the characteristics of the surface.

Material has two different sides:

- a) Lengthwise stripe "rip fabric (even side)"
- b) Transverse thread connection, called satin-side

The satin side is the visible outside of the jumping suit. The satin side must be chinzed. There are no other additional treatments like chemical or mechanic surface changes allowed (for example by aluminium steam, foil application, shaping or others).

Lining fabric

Lining fabric is identical with the outer fabric (material and weight) but only white.

Inside fabric / foam and elastic membrane

The inner life of the material is a three-layer laminate built up of a two 2,1 mm foam layers (volumetric weight ca. 55g) and with an elastic membrane in the middle. This laminate is perforated to reach the defined air permeability.

4.2 Air permeability of the suit material

The material of a jumping suit must show a minimum air permeability which is the same from the outside in and from the inside out. Minimum air permeability is established as follows:

The unstretched fabric must show a medium air permeability of a minimum of 40 litres per m²/sec with 10 mm water pressure.

This value is compulsory at the time of distribution by the manufacturer that means at the moment of plumbing. At controls in competitions it must not be less than 40 litres.

Although usage may result in some stretching of the material, the back portion of the suit must show air permeability as high or higher than the other parts of the suits.

4.3 Underwear

- The thickness of the underwear must not exceed 3,0 mm (cumulative - all layers and parts of the underwear together).
- Air permeability of the underwear must exceed 60 l/m².
- The size, fit and form of underwear must conform the size and shape of the body. Up to a maximum over size tolerance of 10 cm at any measurable body part is permitted.
- No form of a hood is allowed.

4.4 Examination of materials, suits

The guidelines for minimum air permeability established by the FIS Control Procedures/Equipment Working Group in collaboration with the Federal Institute for Materials Control are valid.

Multi-layered materials are accordingly permitted for ski-jumping suits, as long as they conform to the technical specifications and air permeability requirements and all portions of the suit are made from the same material.

5. Crash helmets

Only helmets are permitted whose shell or padding covers the head and ears. The National Ski Associations are advised to provide their teams with only crash helmets, which satisfy the minimum requirements and have been certified by recognized institutes. The shape of the helmet must conform to the shape of the head on all parts of the helmet. The diametrical size of the top surface of the helmet is not allowed to exceed the diameter of the head more than 7 cm.

All helmets must show a smooth top surface for safety reasons.

Visor or integrated, detachable face shields are not allowed.

6. Ski goggles

Ski goggles are devices protecting the eyes against weather and rays with optically correct lenses. Their aim is to guarantee good, contrast-free visibility in all weather conditions. The use of goggles is recommended. Reshaping the ski goggles in order to attain more aerodynamic features is not allowed.

7. Ski gloves

Gloves offer protective covering against weather and external forces. The use of gloves is urgently recommended.

The glove size must correspond to the hand size. Thickness of the material is maximally 5mm.

Only gloves with fingers (for all fingers) are allowed. The gloves may not be fin-shaped.

E. Freestyle competition Equipment

1. Definition

Competition equipment

The term „competition equipment“ embraces all items of equipment used by the athletes in competition skiing, including clothing and implements

that serve a technical function. The entire competition equipment forms a functional unit. In this connection the following points must be observed:

- a) The principle of safety
- b) The principle of fairness

1.1 Competition implements

Competition implements refer to those parts of the equipment, which fulfil essential functions for the competition and which are inseparable from the competition.

Examples: skis, bindings, boots, poles, clothing, helmets, ski goggles.

1.2 Additional equipment (accessories)

Additional equipment (accessories) to competition equipment are those components or implements which have an influence on the technical function of the competition equipment and which are attached directly to the equipment by means of recognised fastenings. Accessories do not perform essential functions for the competitions.

Example: plastic tip covers, additional weights.

1.3 Auxiliary equipment

Auxiliary equipment refers to those components of the competition equipment which do not fulfil an essential function, and which do not fall under the heading of additional equipment.

Example: measuring instruments.

2. Commercial Markings on Equipment

Specifications on page 35 - 38 and refer to ICR 207.

2.1. Freestyle Competition Equipment

Only measurements which are carried out by the appointed FIS equipment measurement experts using the official FIS measurement tools are valid.

The results of measurements carried out at the time are valid and final, irrespective of previous measurements.

2.2 Freestyle skis

2.2.1 Definition

Skis employed in Freestyle competition events where the principal source of motive power is gravity. To assist with directional and speed control, the edges of the running surface are constructed from hard materials and sealed into the ski.

2.2.2 Criteria

2.2.3 Geometric features

There are no limitations or restrictions for ski length and radius.

2.2.4 Ski length

No limitations. (See 4306.1.1 is, 4206.1.1)

- 2.2.5 *Profile width*
No limitations
- 2.2.6 *Radius*
No limitations
- 2.2.7 *Overall height of sectional view*
No limitations.
- 2.2.8 *Camber*
No limitations.
- 2.2.9 *Contour, length and height of shovel*
No limitations
- 2.2.10 *Contour of tail*
No limitations.
- 2.2.11 *Running surface*
No limitations.
- 2.2.12 *Running Groove*
No limitations.
- 2.2.13 *Flexibility*
No limitations with regard to the rigidity in all grades of flex.
- 2.2.14 *Mass*
No limitation with regard to weight and distribution of mass.
- 2.3 Construction**
- 2.3.1 *Type*
No limitation with regard to composite structure.
- 2.3.2 *Ski components*
Running surface: no limitations with regard to material and dimensions.

Torsion box: no limitations with regard to material and dimensions.

Edges: no limitations with regard to material and dimensions.
Of top surface: no limitations with regard to material and dimensions.
Core: no limitations with regard to material.
- 2.3.4 *Durability*
With regard to the mounting of bindings, national norms and at least the „Ö-Norm 4030“, that is the equivalent of DIN- and ISO-norms, must be fulfilled.

3. Additional equipment

No additional equipment is permitted which

- a) makes use of foreign energy (e.g. heaters, chemical energy accumulators, electric batteries, mechanical aids, etc.)
- b) causes or intends to cause changes in the outer conditions of the competition to the disadvantage of fellow competitors (e.g. changes to piste or snow)
- c) increases the risk for the users or other persons, when used for the purpose it was intended for

3.1 Safety bindings

Safety bindings function as strain limiters. That is, these devices transfer specific demands occurring during skiing to an acceptable limit, and when this limit is overstepped, they release their firm hold to the ski. (See 4306.1.2, 4206.1.2, 4008.2.2)

3.2 Anti-vibration plates

Mounting of such plates is permitted under the following conditions:

3.3 Width of ski surface

The plates may not exceed the width of the ski surface.

3.4 Maximum height

For FIS, ENL, Children I and Children II events the maximum height for the season 2008/09 the maximum is 50 mm.

3.5 Ski stoppers

The ski stopper is a catching apparatus for skis, whose function is to stop or bring to a standstill the loose ski following the release of the safety binding within the intermediate area of the skiers fall. In competitions and official training skis without ski stoppers are not permitted. Ski Stoppers must be mounted in such a way as not to impede the operation of the device. The manufacturer is responsible for a perfect function of the ski stoppers.

4. Ski boots

Ski boots are robust footwear developed especially for skiing, offering protection against jolts and bumps as well as injury from ski edges and other external causes. The ski boot encloses the foot firmly, while at the same time allowing the movement necessary for skiing techniques, in that the ankle has the room it needs to move, but at the same time allowing the transfer of every steering movement completely to the ski.

The relevant national and international guidelines and norms establish the requirements.

Thickness of ski boot soles

Distance between the ski boot sole and the base of the heel including all hard and soft parts:

Ladies & Men maximum 45 mm

5. Ski poles

The ski pole is a sports article whose function should aid the skier, facilitate balance and, if necessary, enable stopping. The national and international guidelines and norms establish the minimum requirements for ski pole tips, grips, shaft, baskets, straps, length, etc. Due to risk of injury, metal baskets are not permitted.

6. Competition suits

6.1 Ski Cross

(From Freestyle ICR Ski Cross see page 69; 4511.4)

Ski suits

Ski suits must be two pieces- pants and a separate top. Form-fitting, speed or downhill suits are not permitted.

Non-protruding body protection and padding is recommended.

Protection equipment must be worn on the body. No straps, fastening devices or other methods can be used to tighten the suit material closer to the body. The gap in the material must be a minimum 60mm, measured anywhere around the circumference of the mid thigh, the knee, the top of the ski boot, on the lower body and around the elbow and the bicep on the upper body.

6.2 Moguls

No limitations.

6.3 Aerials

No limitations.

6.4 Halfpipe

No limitations.

6.5 Helmets

The use of helmets is compulsory for all events. (See ICR 3054.6, 4008.2.1, 4306.1.3, 4206.13, 4511.3)

The National Ski Associations shall require their athletes to use helmets which conform to recognized and appropriate standards including CEE 1077 or US 2040, ASTM F2040, etc.

7. Ski goggles

Ski goggles are devices protecting the eyes against weather and rays with optically correct lenses. Their aim is to guarantee good, contrast-free visibility in all weather conditions. The use of ski goggles is recommended.

8. Ski gloves

Gloves offer protective covering against weather and external forces. The wearing of gloves is strongly recommended. Protective padding along the entire length of the glove is permitted. The use of protective guards in the form of shields, which are pulled over the glove, is permitted.

9. Back protectors

9.1 Definition

The back protector is an additional item of equipment, which protects the athlete's back against weather and external forces. The use of back protections is recommended.

Specifications

The back protector must adapt to the anatomical bend of the athlete's spine and lay flat against the body. The top edge of the back protector has to be situated in the area of the spinal column. Fastening of the back protector may take place with a stomach belt, straps or suspenders. The maximum thickness has to be in the middle part and may not exceed 45 mm; the thickness reduces towards the edges of the back protector. The back protector may be worn exclusively under the competition suit.

F. Starting Bibs

Alpine: Downhill / Slalom / Giant Slalom / Super G
Nordic: Cross-Country / Ski Jumping
Examples: See Enclosure 1

1. FIS Specifications for Alpine starting bibs

1.1 Advertising

According to "FIS Advertising Rules"

1.2 Numbers

According to "FIS Advertising Rules"

1.3 Assignment

Starting bibs must be assigned as follows:

Ladies sizes: with elastic band
Men's sizes: with elastic band

1.4 Fabric, Material

T-shirt starting bibs, 100% Polyester / Interlock

1.5 Elasticity (stretch)

Measured on a piece of material 10 cm wide:
Stretch ability in the width 24 cm.

1.6 Seams, Sewing

Side seams: Material is sewn together, hemmed and stitched - overlook.
Neckline and armholes are trimmed with edging and double-stitched.
Waistband with 2 cm wide seam, double-stitched with an elastic band pulled through.
(See enclosure 1)

2. FIS Specifications for Cross-Country starting bibs

2.1 Advertising

According to "FIS Advertising Rules"

2.2 Numbers

According to "FIS Advertising Rules"

2.3 Assignment

Starting bibs must be assigned as follows and must be cut in such a way that the skier's shoulders are allowed free movement:

Ladies size: without elastic band

Men's size: without elastic band.

2.4 Fabric, material

T-shirt starting bibs in smooth material quality 100% Polyester / Interlock or 100 % polyester knitwear (meshed or non-meshed).

2.5 Elasticity (stretch)

Meshed starting bibs: measured on a piece of fabric 10 cm wide:

Stretch ability in the width 18,5 cm

None meshed starting bibs: measured on a piece of fabric 10 cm wide:

Stretch ability in the width: 24 cm

(See enclosure 1)

3. FIS Specifications for Ski-Jumping starting bibs

3.1 Advertising

According to "FIS Advertising Rules"

3.2 Numbers

According to "FIS Advertising Rules"

3.3 Assignment

Starting bibs are assigned to the men in men's sizes.

3.4 Fabric, material

T-Shirt starting bibs 100 % Polyester with an air permeability of 40 litres per m²/sec under 10 mm of water pressure.

3.5 Elasticity (stretch)

Measured on a piece of fabric 10 cm wide:

Stretch ability in the width 24 cm.

3.6. Seams, sewing

Side seams: material is sewn together, hemmed and stitched - overlook.

Neckline and armholes are trimmed with edging and double-stitched.

Waistband with 2 cm wide seam, double-stitched (see enclosure 1).

Procedures for the Acceptance of Innovations in Competition Equipment

Article 222.4 of the ICR reads as follows:

New developments must be submitted by May 1st, at the latest, for the following season. The first year new developments can only be approved provisionally for the following season and must be finally confirmed prior to the subsequent competition season.

1. Eligible applicants

- a) Manufactures or distributors of the innovation
- b) National associations
- c) Members of the Committee for Competition Equipment

2. Items for application

Any fundamental innovation or further development, which is to be used as equipment in competition skiing, may be submitted for acceptance. It is solely the responsibility of the Committee for Competition Equipment to decide whether an innovation or further development conforms to the FIS „Competition Equipment Specifications“. The Committee can at any time, however, arrange the execution of an application with regard to items of equipment to be used in competition sport, in accordance with the decisions of these guidelines.

3. Prototype, samples

The application must be dealt with in such a way that the innovation is described in detail. A prototype or sample must be included with the application. Relevant reports by scientific experts, as well as reports of experiences made by trainers or participants are to be submitted.

4. Decisions of the Committee for Competition Equipment

The Committee for Competition Equipment deals with these applications at its next meeting. If the Committee is of the opinion that the item being presented conforms fully to the valid Specifications for Competition Equipment, this decision will be set down in a relevant solution.

If the Committee reaches the conclusion that the innovation could be accepted in accordance with the relevant principles and decisions of the FIS Specifications for Competition Equipment in competition sports, the innovation can be provisionally approved for testing for the duration of the following season.

This approval can, however, also be conditionally accepted. On the grounds of fairness, exceptions can be made for certain competitions (Olympic Winter Games, World Championships, etc.).

However, the Committee for Competition Equipment can also take the following measures before provisional approval. These can be dealt with individually or together:

- a) requesting applicants for further information, such as reports by experts and technical data
- b) seeking reactions of the FIS Technical Committees. These opinions must be submitted in writing and take the following factors into consideration:
 - 1. explanation with regard to the usefulness and necessity of the innovation
 - 2. opinions with regard to the safety of the innovation
 - 3. assurance that in accepting the innovation, the principle of fairness will be guaranteed
- c) seeking reports by experts and other information through the Committee for Competition Equipment itself.

Should the innovation not conform to the principles of the FIS Specifications for Competition Equipment, either through the application itself, or in the course of the procedures, the use of the innovation in question will be forbidden for competition sport. This will also occur if, during the item's probation period, circumstances result which lead the Committee to decide that the innovation does not conform to the principles of the FIS Specifications for Competition Equipment. In such a case, the provisional approval will be rescinded, effective immediately.

5. FIS Council

Changes in the Specifications for Competition Equipment can be proposed to the FIS Council only through the Committee for Competition Equipment - either by means of an initiative from the Committee itself or through an application of one of the National Ski Associations or Technical Committees to the Committee for Competition Equipment.

Ski Jumping - Men:
without elastic band

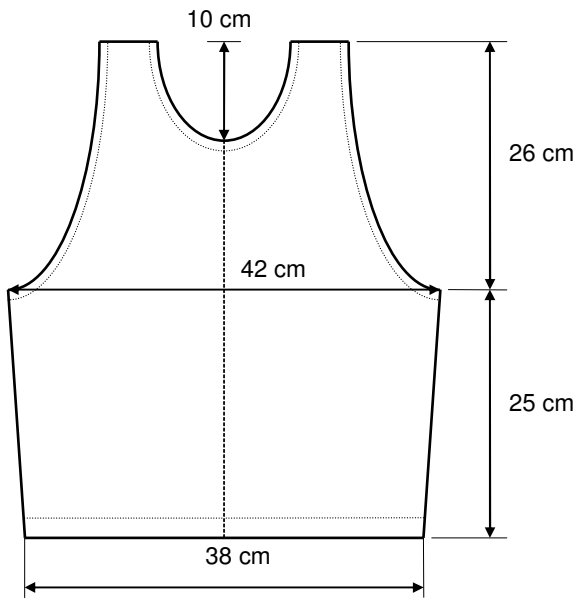

Ski Jumping - Ladies:
Without elastic band

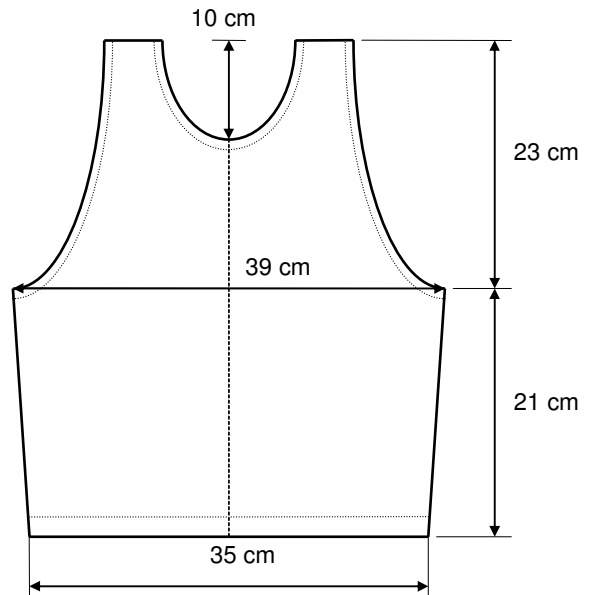

Alpine, women: with elastic

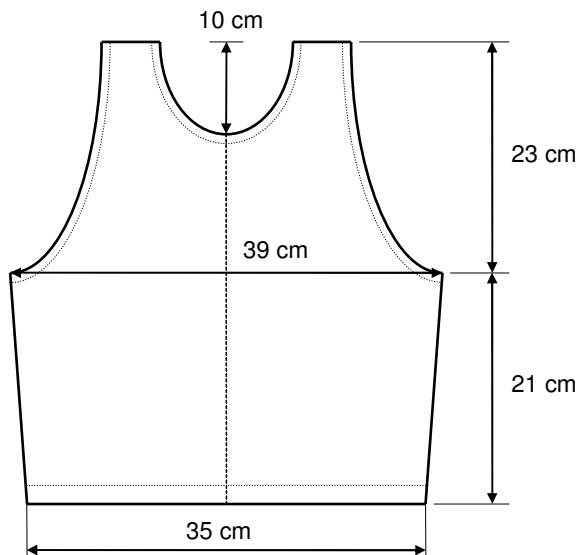

Alpine, men: with elastic

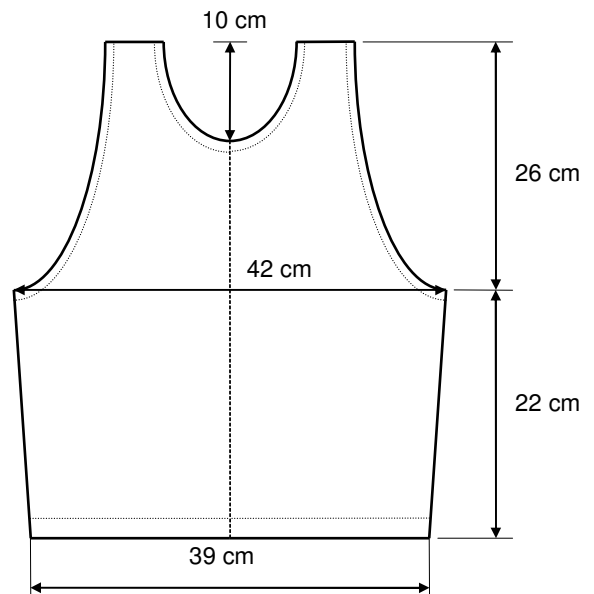

Freestyle Bibs

Aerials – Ladies
with elastic band

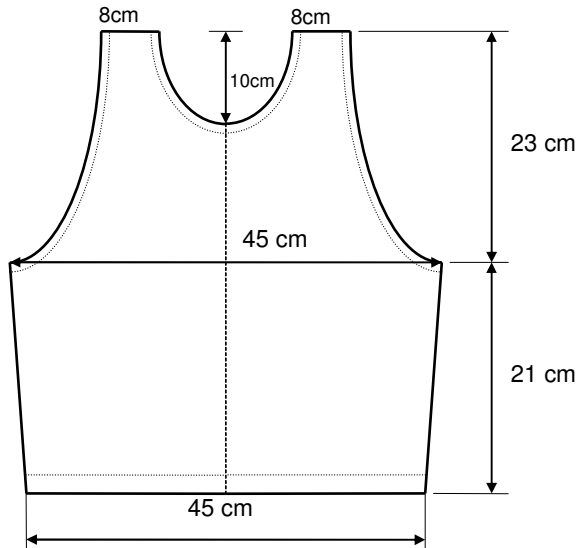

Aerials – Men
with elastic band

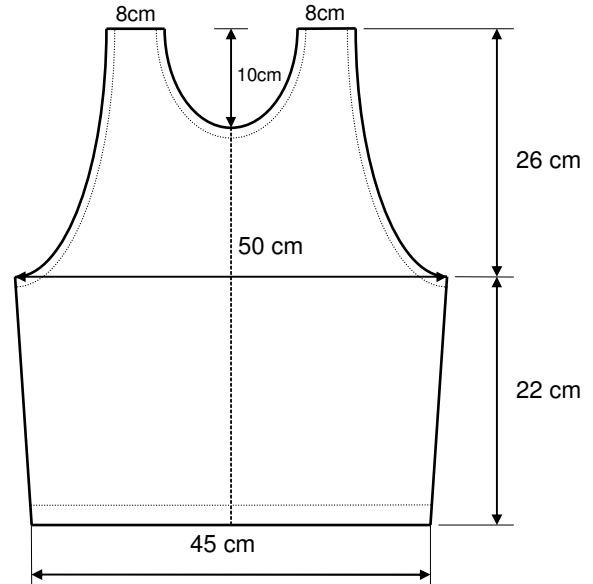

Moguls, Halfpipe, Ski Cross – Ladies
open sides and 4 elastic straps

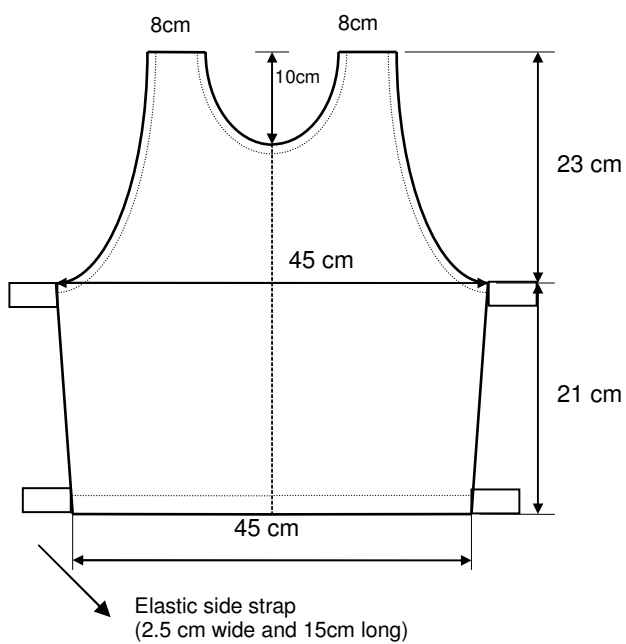

Moguls, HalfPipe, Ski Cross – Men
open sides and 4 elastic straps

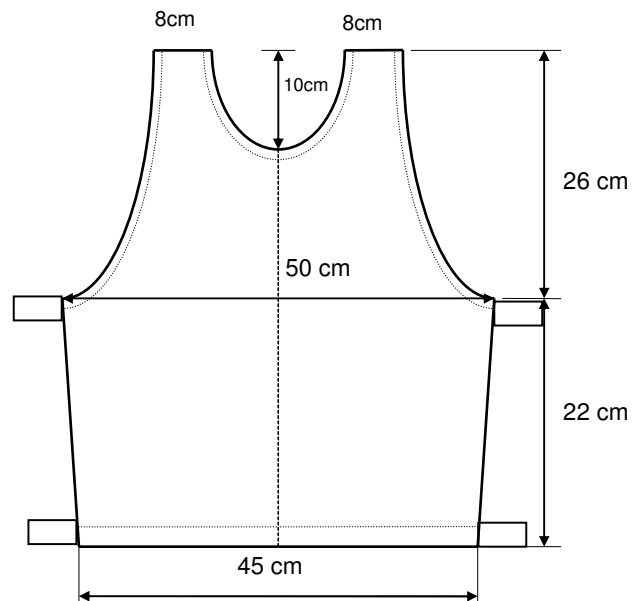

Cross-Country, men:
Meshed without elastic

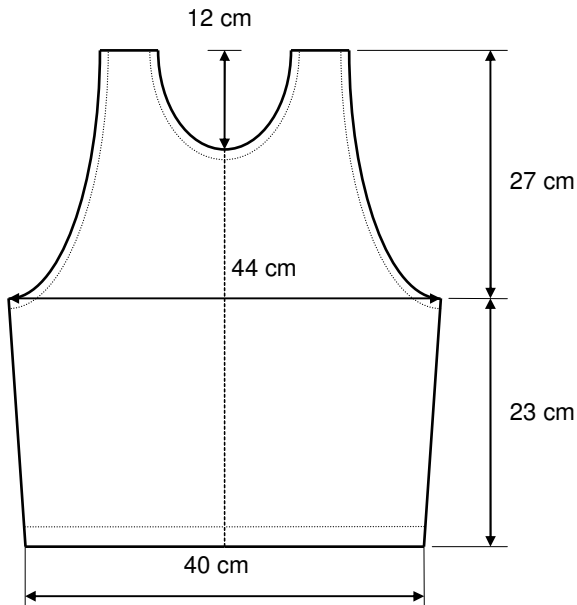

Cross-Country women:
Meshed without elastic

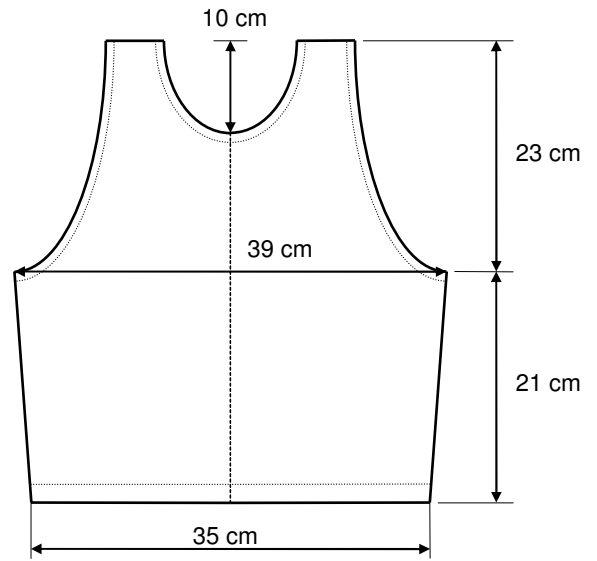

Cross-Country,
Women: without elastic

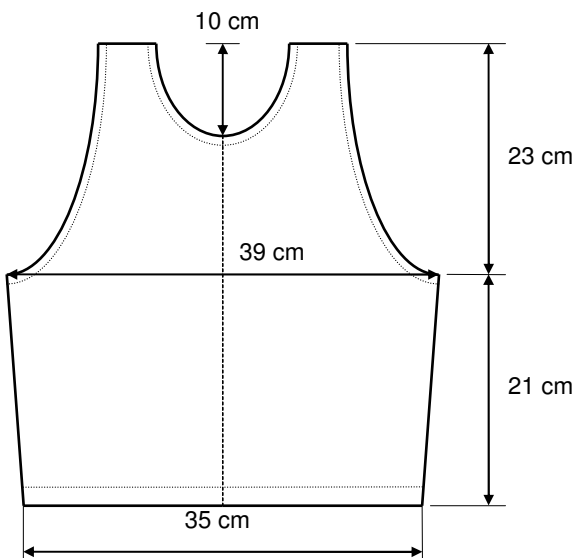

Cross-Country,
Men: without elastic

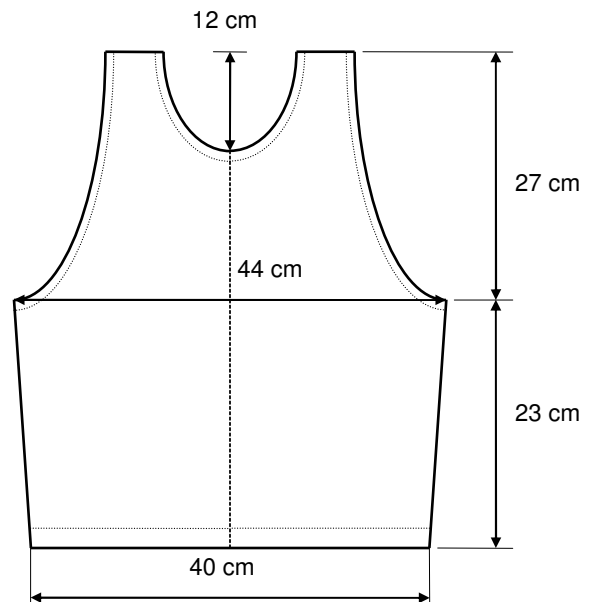

Measurement table for ski length and weight - Season 2006/07												
Körpergrösse	A		B		C		D		E		F	
	Gewicht mit Anzug und	Skilänge	Gewicht mit Anzug und Schuhen	Skilänge	Gewicht mit Anzug und	Skilänge	Gewicht mit Anzug und	Skilänge	Gewicht mit Anzug und	Skilänge	Gewicht mit Anzug und	Skilänge
Body Height	Weight with suit and boots	Ski length	Weight with suit and boots	Ski length	Weight with suit and boots	Ski length	Weight with suit and boots	Ski length	Weight with suit and boots	Ski length	Weight with suit and boots	Ski length
BMI / %	20.000	146.0	19.875	145.5	19.750	145.0	19.625	144.5	19.500	144.0	19.375	143.5
cm	kg	cm	kg	cm	kg	cm	kg	cm	kg	cm	kg	cm
140	39.2	204	39.0	204	38.7	203	38.5	202	38.2	202	38.0	201
141	39.8	206	39.5	205	39.3	204	39.0	204	38.8	203	38.5	202
142	40.3	207	40.1	207	39.8	206	39.6	205	39.3	204	39.1	204
143	40.9	209	40.6	208	40.4	207	40.1	207	39.9	206	39.6	205
144	41.5	210	41.2	210	41.0	209	40.7	208	40.4	207	40.2	207
145	42.1	212	41.8	211	41.5	210	41.3	210	41.0	209	40.7	208
146	42.6	213	42.4	212	42.1	212	41.8	211	41.6	210	41.3	210
147	43.2	215	42.9	214	42.7	213	42.4	212	42.1	212	41.9	211
148	43.8	216	43.5	215	43.3	215	43.0	214	42.7	213	42.4	212
149	44.4	218	44.1	217	43.8	216	43.6	215	43.3	215	43.0	214
150	45.0	219	44.7	218	44.4	218	44.2	217	43.9	216	43.6	215
151	45.6	220	45.3	220	45.0	219	44.7	218	44.5	217	44.2	217
152	46.2	222	45.9	221	45.6	220	45.3	220	45.1	219	44.8	218
153	46.8	223	46.5	223	46.2	222	45.9	221	45.6	220	45.4	220
154	47.4	225	47.1	224	46.8	223	46.5	223	46.2	222	45.9	221
155	48.1	226	47.7	226	47.4	225	47.1	224	46.8	223	46.5	222
156	48.7	228	48.4	227	48.1	226	47.8	225	47.5	225	47.2	224
157	49.3	229	49.0	228	48.7	228	48.4	227	48.1	226	47.8	225
158	49.9	231	49.6	230	49.3	229	49.0	228	48.7	228	48.4	227
159	50.6	232	50.2	231	49.9	231	49.6	230	49.3	229	49.0	228
160	51.2	234	50.9	233	50.6	232	50.2	231	49.9	230	49.6	230
161	51.8	235	51.5	234	51.2	233	50.9	233	50.5	232	50.2	231
162	52.5	237	52.2	236	51.8	235	51.5	234	51.2	233	50.8	232
163	53.1	238	52.8	237	52.5	236	52.1	236	51.8	235	51.5	234
164	53.8	239	53.5	239	53.1	238	52.8	237	52.4	236	52.1	235
165	54.5	241	54.1	240	53.8	239	53.4	238	53.1	238	52.7	237
166	55.1	242	54.8	242	54.4	241	54.1	240	53.7	239	53.4	238
167	55.8	244	55.4	243	55.1	242	54.7	241	54.4	240	54.0	240
168	56.4	245	56.1	244	55.7	244	55.4	243	55.0	242	54.7	241
169	57.1	247	56.8	246	56.4	245	56.1	244	55.7	243	55.3	243
170	57.8	248	57.4	247	57.1	247	56.7	246	56.4	245	56.0	244
171	58.5	250	58.1	249	57.8	248	57.4	247	57.0	246	56.7	245
172	59.2	251	58.8	250	58.4	249	58.1	249	57.7	248	57.3	247
173	59.9	253	59.5	252	59.1	251	58.7	250	58.4	249	58.0	248
174	60.6	254	60.2	253	59.8	252	59.4	251	59.0	251	58.7	250
175	61.3	256	60.9	255	60.5	254	60.1	253	59.7	252	59.3	251
176	62.0	257	61.6	256	61.2	255	60.8	254	60.4	253	60.0	253
177	62.7	258	62.3	258	61.9	257	61.5	256	61.1	255	60.7	254
178	63.4	260	63.0	259	62.6	258	62.2	257	61.8	256	61.4	255
179	64.1	261	63.7	260	63.3	260	62.9	259	62.5	258	62.1	257
180	64.8	263	64.4	262	64.0	261	63.6	260	63.2	259	62.8	258
181	65.5	264	65.1	263	64.7	262	64.3	262	63.9	261	63.5	260
182	66.2	266	65.8	265	65.4	264	65.0	263	64.6	262	64.2	261
183	67.0	267	66.6	266	66.1	265	65.7	264	65.3	264	64.9	263
184	67.7	269	67.3	268	66.9	267	66.4	266	66.0	265	65.6	264
185	68.5	270	68.0	269	67.6	268	67.2	267	66.7	266	66.3	265
186	69.2	272	68.8	271	68.3	270	67.9	269	67.5	268	67.0	267
187	69.9	273	69.5	272	69.1	271	68.6	270	68.2	269	67.8	268
188	70.7	274	70.2	274	69.8	273	69.4	272	68.9	271	68.5	270
189	71.4	276	71.0	275	70.5	274	70.1	273	69.7	272	69.2	271
190	72.2	277	71.7	276	71.3	276	70.8	275	70.4	274	69.9	273
191	73.0	279	72.5	278	72.0	277	71.6	276	71.1	275	70.7	274
192	73.7	280	73.3	279	72.8	278	72.3	277	71.9	276	71.4	276
193	74.5	282	74.0	281	73.6	280	73.1	279	72.6	278	72.2	277
194	75.3	283	74.8	282	74.3	281	73.9	280	73.4	279	72.9	278
195	76.1	285	75.6	284	75.1	283	74.6	282	74.1	281	73.7	280
196	76.8	286	76.4	285	75.9	284	75.4	283	74.9	282	74.4	281
197	77.6	288	77.1	287	76.6	286	76.2	285	75.7	284	75.2	283
198	78.4	289	77.9	288	77.4	287	76.9	286	76.4	285	76.0	284
199	79.2	291	78.7	290	78.2	289	77.7	288	77.2	287	76.7	286
200	80.0	292	79.5	291	79.0	290	78.5	289	78.0	288	77.5	287

Körpergröße	G		H		I		J		K		L	
	Gewicht mit Anzug und	Skilänge	Gewicht mit Anzug und	Skilänge	Gewicht mit Anzug und	Skilänge	Gewicht mit Anzug und	Skilänge	Gewicht mit Anzug und	Skilänge	Gewicht mit Anzug und	Skilänge
Body Height	Weight with suit and boots	Ski length	Weight with suit and boots	Ski length	Weight with suit and boots	Ski length	Weight with suit and boots	Ski length	Weight with suit and boots	Ski length	Weight with suit and boots	Ski length
BMI / %	19.250	143.0	19.125	142.5	19.000	142.0	18.875	141.5	18.750	141.0	18.625	140.5
cm	kg	cm	kg	cm	kg	cm	kg	cm	kg	cm	kg	cm
140	37.7	200	37.5	200	37.2	199	37.0	198	36.8	197	36.5	197
141	38.3	202	38.0	201	37.8	200	37.5	200	37.3	199	37.0	198
142	38.8	203	38.6	202	38.3	202	38.1	201	37.8	200	37.6	200
143	39.4	204	39.1	204	38.9	203	38.6	202	38.3	202	38.1	201
144	39.9	206	39.7	205	39.4	204	39.1	204	38.9	203	38.6	202
145	40.5	207	40.2	207	39.9	206	39.7	205	39.4	204	39.2	204
146	41.0	209	40.8	208	40.5	207	40.2	207	40.0	206	39.7	205
147	41.6	210	41.3	209	41.1	209	40.8	208	40.5	207	40.2	207
148	42.2	212	41.9	211	41.6	210	41.3	209	41.1	209	40.8	208
149	42.7	213	42.5	212	42.2	212	41.9	211	41.6	210	41.3	209
150	43.3	215	43.0	214	42.8	213	42.5	212	42.2	212	41.9	211
151	43.9	216	43.6	215	43.3	214	43.0	214	42.8	213	42.5	212
152	44.5	217	44.2	217	43.9	216	43.6	215	43.3	214	43.0	214
153	45.1	219	44.8	218	44.5	217	44.2	216	43.9	216	43.6	215
154	45.7	220	45.4	219	45.1	219	44.8	218	44.5	217	44.2	216
155	46.2	222	45.9	221	45.6	220	45.3	219	45.0	219	44.7	218
156	46.8	223	46.5	222	46.2	222	45.9	221	45.6	220	45.3	219
157	47.4	225	47.1	224	46.8	223	46.5	222	46.2	221	45.9	221
158	48.1	226	47.7	225	47.4	224	47.1	224	46.8	223	46.5	222
159	48.7	227	48.3	227	48.0	226	47.7	225	47.4	224	47.1	223
160	49.3	229	49.0	228	48.6	227	48.3	226	48.0	226	47.7	225
161	49.9	230	49.6	229	49.2	229	48.9	228	48.6	227	48.3	226
162	50.5	232	50.2	231	49.9	230	49.5	229	49.2	228	48.9	228
163	51.1	233	50.8	232	50.5	231	50.1	231	49.8	230	49.5	229
164	51.8	235	51.4	234	51.1	233	50.8	232	50.4	231	50.1	230
165	52.4	236	52.1	235	51.7	234	51.4	233	51.0	233	50.7	232
166	53.0	237	52.7	237	52.4	236	52.0	235	51.7	234	51.3	233
167	53.7	239	53.3	238	53.0	237	52.6	236	52.3	235	51.9	235
168	54.3	240	54.0	239	53.6	239	53.3	238	52.9	237	52.6	236
169	55.0	242	54.6	241	54.3	240	53.9	239	53.6	238	53.2	237
170	55.6	243	55.3	242	54.9	241	54.5	241	54.2	240	53.8	239
171	56.3	245	55.9	244	55.6	243	55.2	242	54.8	241	54.5	240
172	56.9	246	56.6	245	56.2	244	55.8	243	55.5	243	55.1	242
173	57.6	247	57.2	247	56.9	246	56.5	245	56.1	244	55.7	243
174	58.3	249	57.9	248	57.5	247	57.1	246	56.8	245	56.4	244
175	59.0	250	58.6	249	58.2	249	57.8	248	57.4	247	57.0	246
176	59.6	252	59.2	251	58.9	250	58.5	249	58.1	248	57.7	247
177	60.3	253	59.9	252	59.5	251	59.1	250	58.7	250	58.4	249
178	61.0	255	60.6	254	60.2	253	59.8	252	59.4	251	59.0	250
179	61.7	256	61.3	255	60.9	254	60.5	253	60.1	252	59.7	251
180	62.4	257	62.0	257	61.6	256	61.2	255	60.8	254	60.3	253
181	63.1	259	62.7	258	62.2	257	61.8	256	61.4	255	61.0	254
182	63.8	260	63.3	259	62.9	258	62.5	258	62.1	257	61.7	256
183	64.5	262	64.0	261	63.6	260	63.2	259	62.8	258	62.4	257
184	65.2	263	64.7	262	64.3	261	63.9	260	63.5	259	63.1	259
185	65.9	265	65.5	264	65.0	263	64.6	262	64.2	261	63.7	260
186	66.6	266	66.2	265	65.7	264	65.3	263	64.9	262	64.4	261
187	67.3	267	66.9	266	66.4	266	66.0	265	65.6	264	65.1	263
188	68.0	269	67.6	268	67.2	267	66.7	266	66.3	265	65.8	264
189	68.8	270	68.3	269	67.9	268	67.4	267	67.0	266	66.5	266
190	69.5	272	69.0	271	68.6	270	68.1	269	67.7	268	67.2	267
191	70.2	273	69.8	272	69.3	271	68.9	270	68.4	269	67.9	268
192	71.0	275	70.5	274	70.0	273	69.6	272	69.1	271	68.7	270
193	71.7	276	71.2	275	70.8	274	70.3	273	69.8	272	69.4	271
194	72.4	277	72.0	276	71.5	275	71.0	275	70.6	274	70.1	273
195	73.2	279	72.7	278	72.2	277	71.8	276	71.3	275	70.8	274
196	74.0	280	73.5	279	73.0	278	72.5	277	72.0	276	71.5	275
197	74.7	282	74.2	281	73.7	280	73.3	279	72.8	278	72.3	277
198	75.5	283	75.0	282	74.5	281	74.0	280	73.5	279	73.0	278
199	76.2	285	75.7	284	75.2	283	74.7	282	74.3	281	73.8	280
200	77.0	286	76.5	285	76.0	284	75.5	283	75.0	282	74.5	281

Körpergröße Body Height	M		N		O		P		R		S		T	
	Gewicht mit Anzug und boots Weight with suit and boots	Skilänge Ski length	Gewicht mit Anzug und boots Weight with suit and boots	Skilänge Ski length	Gewicht mit Anzug und boots Weight with suit and boots	Skilänge Ski length	Gewicht mit Anzug und boots Weight with suit and boots	Skilänge Ski length	Gewicht mit Anzug und boots Weight with suit and boots	Skilänge Ski length	Gewicht mit Anzug und boots Weight with suit and boots	Skilänge Ski length	Gewicht mit Anzug und boots Weight with suit and boots	Skilänge Ski length
BMI / %	18.500	140.0	18.375	139.5	18.250	139.0	18.125	138.5	18.000	138.0	17.875	137.5	17.750	137.0
cm	kg	cm	kg	cm	kg	cm	kg	cm	kg	cm	kg	cm	kg	cm
140	36.3	196	36.0	195	35.8	195	35.5	194	35.3	193	35.0	193	34.8	192
141	36.8	197	36.5	197	36.3	196	36.0	195	35.8	195	35.5	194	35.3	193
142	37.3	199	37.1	198	36.8	197	36.5	197	36.3	196	36.0	195	35.8	195
143	37.8	200	37.6	199	37.3	199	37.1	198	36.8	197	36.6	197	36.3	196
144	38.4	202	38.1	201	37.8	200	37.6	199	37.3	199	37.1	198	36.8	197
145	38.9	203	38.6	202	38.4	202	38.1	201	37.8	200	37.6	199	37.3	199
146	39.4	204	39.2	204	38.9	203	38.6	202	38.4	201	38.1	201	37.8	200
147	40.0	206	39.7	205	39.4	204	39.2	204	38.9	203	38.6	202	38.4	201
148	40.5	207	40.2	206	40.0	206	39.7	205	39.4	204	39.2	204	38.9	203
149	41.1	209	40.8	208	40.5	207	40.2	206	40.0	206	39.7	205	39.4	204
150	41.6	210	41.3	209	41.1	209	40.8	208	40.5	207	40.2	206	39.9	206
151	42.2	211	41.9	211	41.6	210	41.3	209	41.0	208	40.8	208	40.5	207
152	42.7	213	42.5	212	42.2	211	41.9	211	41.6	210	41.3	209	41.0	208
153	43.3	214	43.0	213	42.7	213	42.4	212	42.1	211	41.8	210	41.6	210
154	43.9	216	43.6	215	43.3	214	43.0	213	42.7	213	42.4	212	42.1	211
155	44.4	217	44.1	216	43.8	215	43.5	215	43.2	214	42.9	213	42.6	212
156	45.0	218	44.7	218	44.4	217	44.1	216	43.8	215	43.5	215	43.2	214
157	45.6	220	45.3	219	45.0	218	44.7	217	44.4	217	44.1	216	43.8	215
158	46.2	221	45.9	220	45.6	220	45.2	219	44.9	218	44.6	217	44.3	216
159	46.8	223	46.5	222	46.1	221	45.8	220	45.5	219	45.2	219	44.9	218
160	47.4	224	47.0	223	46.7	222	46.4	222	46.1	221	45.8	220	45.4	219
161	48.0	225	47.6	225	47.3	224	47.0	223	46.7	222	46.3	221	46.0	221
162	48.6	227	48.2	226	47.9	225	47.6	224	47.2	224	46.9	223	46.6	222
163	49.2	228	48.8	227	48.5	227	48.2	226	47.8	225	47.5	224	47.2	223
164	49.8	230	49.4	229	49.1	228	48.7	227	48.4	226	48.1	226	47.7	225
165	50.4	231	50.0	230	49.7	229	49.3	229	49.0	228	48.7	227	48.3	226
166	51.0	232	50.6	232	50.3	231	49.9	230	49.6	229	49.3	228	48.9	227
167	51.6	234	51.2	233	50.9	232	50.5	231	50.2	230	49.9	230	49.5	229
168	52.2	235	51.9	234	51.5	234	51.2	233	50.8	232	50.5	231	50.1	230
169	52.8	237	52.5	236	52.1	235	51.8	234	51.4	233	51.1	232	50.7	232
170	53.5	238	53.1	237	52.7	236	52.4	235	52.0	235	51.7	234	51.3	233
171	54.1	239	53.7	239	53.4	238	53.0	237	52.6	236	52.3	235	51.9	234
172	54.7	241	54.4	240	54.0	239	53.6	238	53.3	237	52.9	237	52.5	236
173	55.4	242	55.0	241	54.6	240	54.2	240	53.9	239	53.5	238	53.1	237
174	56.0	244	55.6	243	55.3	242	54.9	241	54.5	240	54.1	239	53.7	238
175	56.7	245	56.3	244	55.9	243	55.5	242	55.1	242	54.7	241	54.4	240
176	57.3	246	56.9	246	56.5	245	56.1	244	55.8	243	55.4	242	55.0	241
177	58.0	248	57.6	247	57.2	246	56.8	245	56.4	244	56.0	243	55.6	242
178	58.6	249	58.2	248	57.8	247	57.4	247	57.0	246	56.6	245	56.2	244
179	59.3	251	58.9	250	58.5	249	58.1	248	57.7	247	57.3	246	56.9	245
180	59.9	252	59.5	251	59.1	250	58.7	249	58.3	248	57.9	248	57.5	247
181	60.6	253	60.2	252	59.8	252	59.4	251	59.0	250	58.6	249	58.2	248
182	61.3	255	60.9	254	60.5	253	60.0	252	59.6	251	59.2	250	58.8	249
183	62.0	256	61.5	255	61.1	254	60.7	253	60.3	253	59.9	252	59.4	251
184	62.6	258	62.2	257	61.8	256	61.4	255	60.9	254	60.5	253	60.1	252
185	63.3	259	62.9	258	62.5	257	62.0	256	61.6	255	61.2	254	60.7	253
186	64.0	260	63.6	259	63.1	259	62.7	258	62.3	257	61.8	256	61.4	255
187	64.7	262	64.3	261	63.8	260	63.4	259	62.9	258	62.5	257	62.1	256
188	65.4	263	64.9	262	64.5	261	64.1	260	63.6	259	63.2	259	62.7	258
189	66.1	265	65.6	264	65.2	263	64.7	262	64.3	261	63.9	260	63.4	259
190	66.8	266	66.3	265	65.9	264	65.4	263	65.0	262	64.5	261	64.1	260
191	67.5	267	67.0	266	66.6	265	66.1	265	65.7	264	65.2	263	64.8	262
192	68.2	269	67.7	268	67.3	267	66.8	266	66.4	265	65.9	264	65.4	263
193	68.9	270	68.4	269	68.0	268	67.5	267	67.0	266	66.6	265	66.1	264
194	69.6	272	69.2	271	68.7	270	68.2	269	67.7	268	67.3	267	66.8	266
195	70.3	273	69.9	272	69.4	271	68.9	270	68.4	269	68.0	268	67.5	267
196	71.1	274	70.6	273	70.1	272	69.6	271	69.1	270	68.7	270	68.2	269
197	71.8	276	71.3	275	70.8	274	70.3	273	69.9	272	69.4	271	68.9	270
198	72.5	277	72.0	276	71.5	275	71.1	274	70.6	273	70.1	272	69.6	271
199	73.3	279	72.8	278	72.3	277	71.8	276	71.3	275	70.8	274	70.3	273
200	74.0	280	73.5	279	73.0	278	72.5	277	72.0	276	71.5	275	71.0	274

Measurement table for mounting of Ski Jumping Bindings

Körpergr. in cm	146%	57% der Gesamtlänge	Körpergr. in cm	146%	57% der Gesamtlänge
<i>Body size in cm</i>	<i>146%</i>	<i>57% of total length</i>	<i>Body size in cm</i>	<i>146%</i>	<i>57% of total length</i>
145	212	121	173	253	144
146	213	121	174	254	145
	214	122		255	145
147	215	123	175	256	146
148	216	123	176	257	146
	217	124	177	258	147
149	218	124		259	148
150	219	125	178	260	148
151	220	125	179	261	149
	221	126		262	149
152	222	127	180	263	150
153	223	127	181	264	150
	224	128		265	151
154	225	128	182	266	152
155	226	129	183	267	152
	227	129		268	153
156	228	130	184	269	153
157	229	131	185	270	154
	230	132		271	154
158	231	132	186	272	155
159	232	132	187	273	156
	233	133	188	274	156
160	234	133		275	157
161	235	134	189	276	157
	236	135	190	277	158
162	237	135		278	158
163	238	136	191	279	159
164	239	136	192	280	160
	240	137		281	160
165	241	137	193	282	161
166	242	138	194	283	161
	243	139		284	162
167	244	139	195	285	162
168	245	140	196	286	163
	246	140		287	164
169	247	141	197	288	164
170	248	141	198	289	165
	249	142		290	165
171	250	143	199	291	166
172	251	143	200	292	166
	252	144			

Article 1.2.1.2: Precision of the Profile Width

L	Ski length
a	max. width at front portion = 115 mm
b	max. width at 57% of front portion (f) = 105 mm
c	max. width at tail portion = 115 mm
d	max. length between tip and begin of sidecut = 300 mm
e	max. length between tail and begin of sidecut = 150 mm
f	control point of b

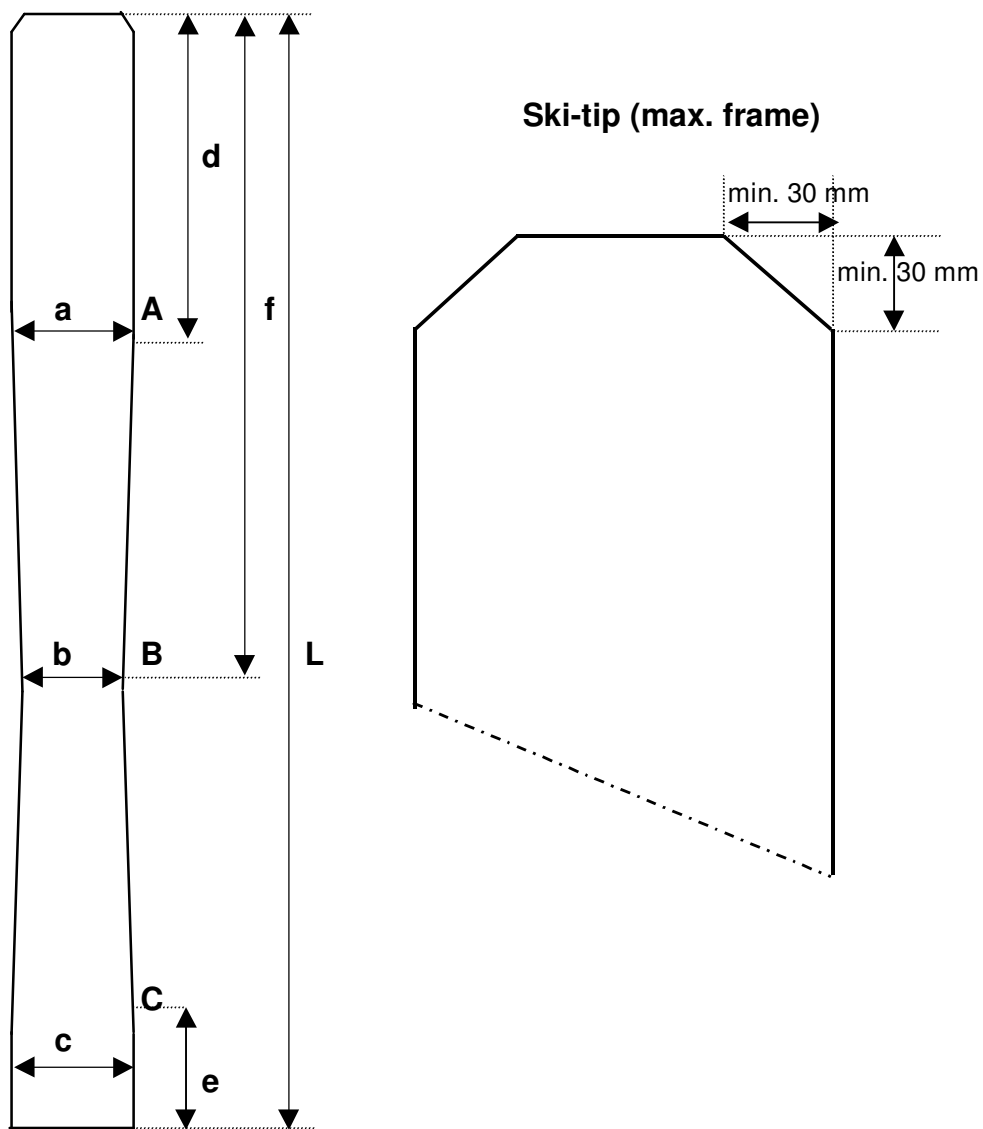

Skisprung Anzüge

Standardisierte Messungskontrollpunkte und Anzahl Materialteile aus denen ein Anzug bestehen darf.

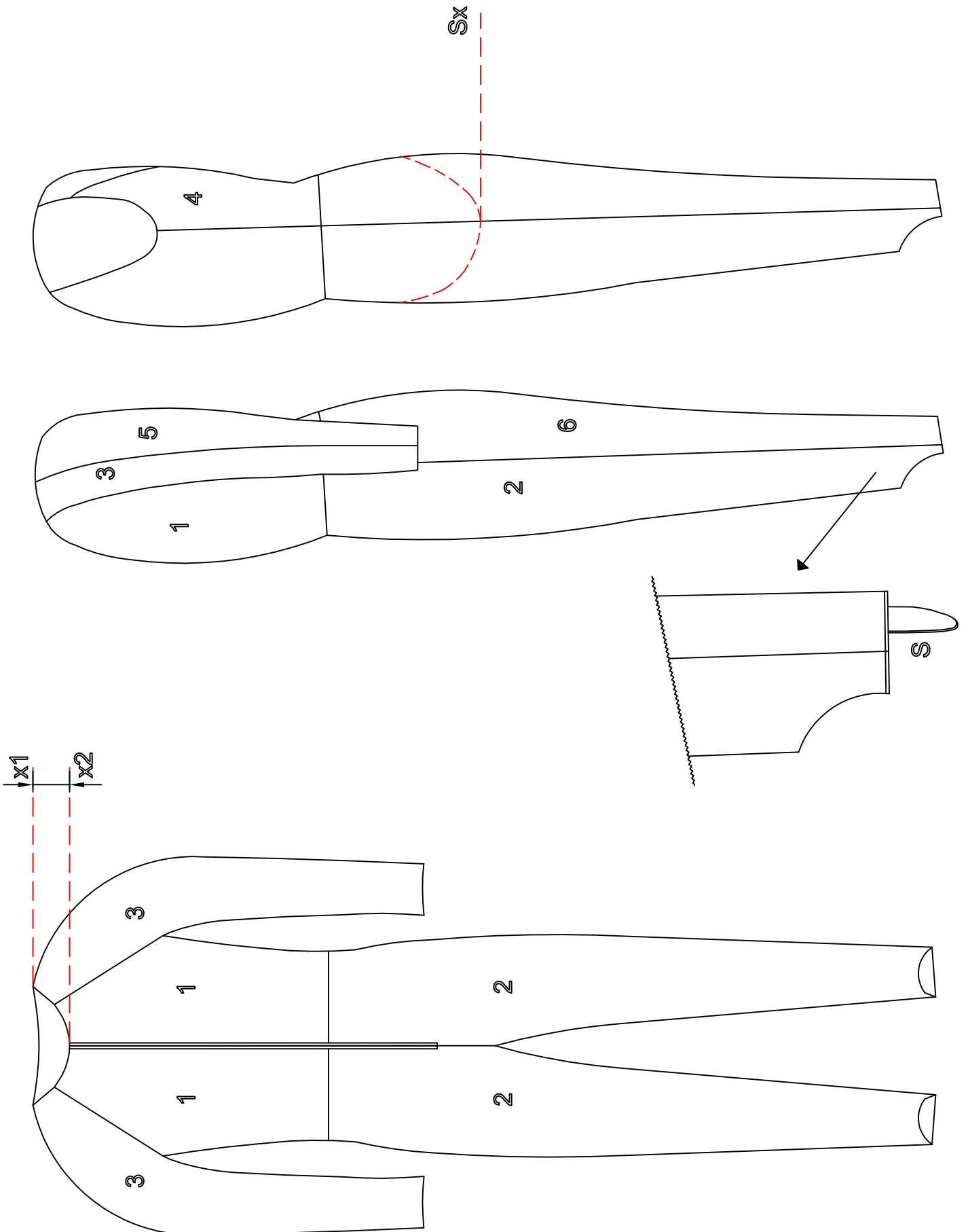

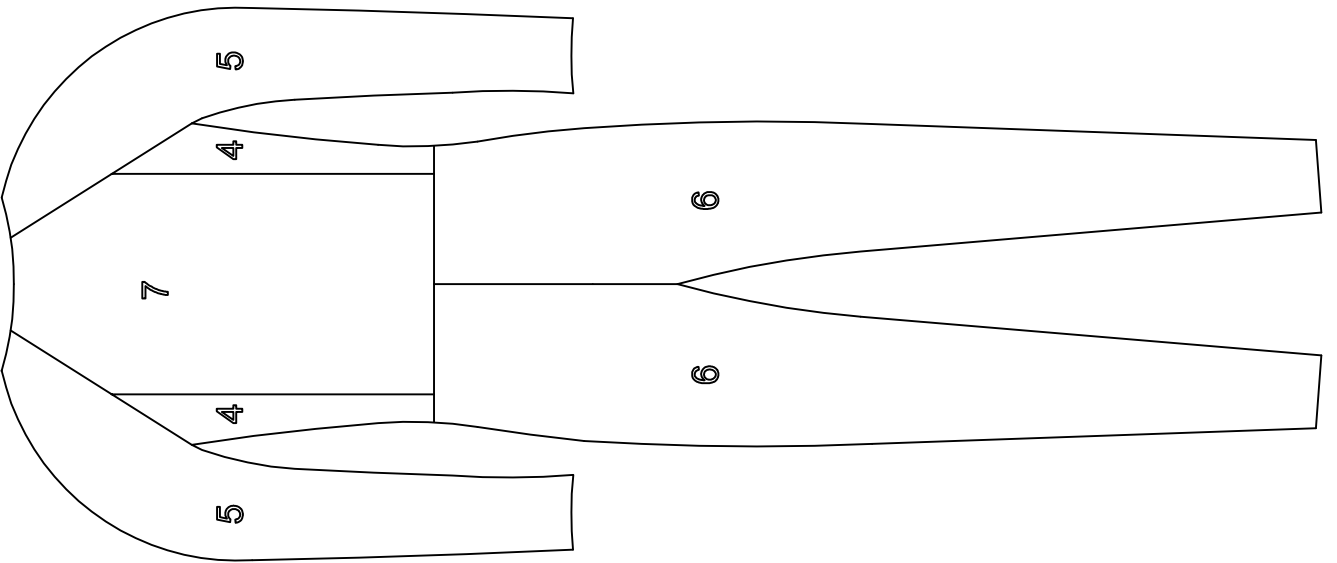
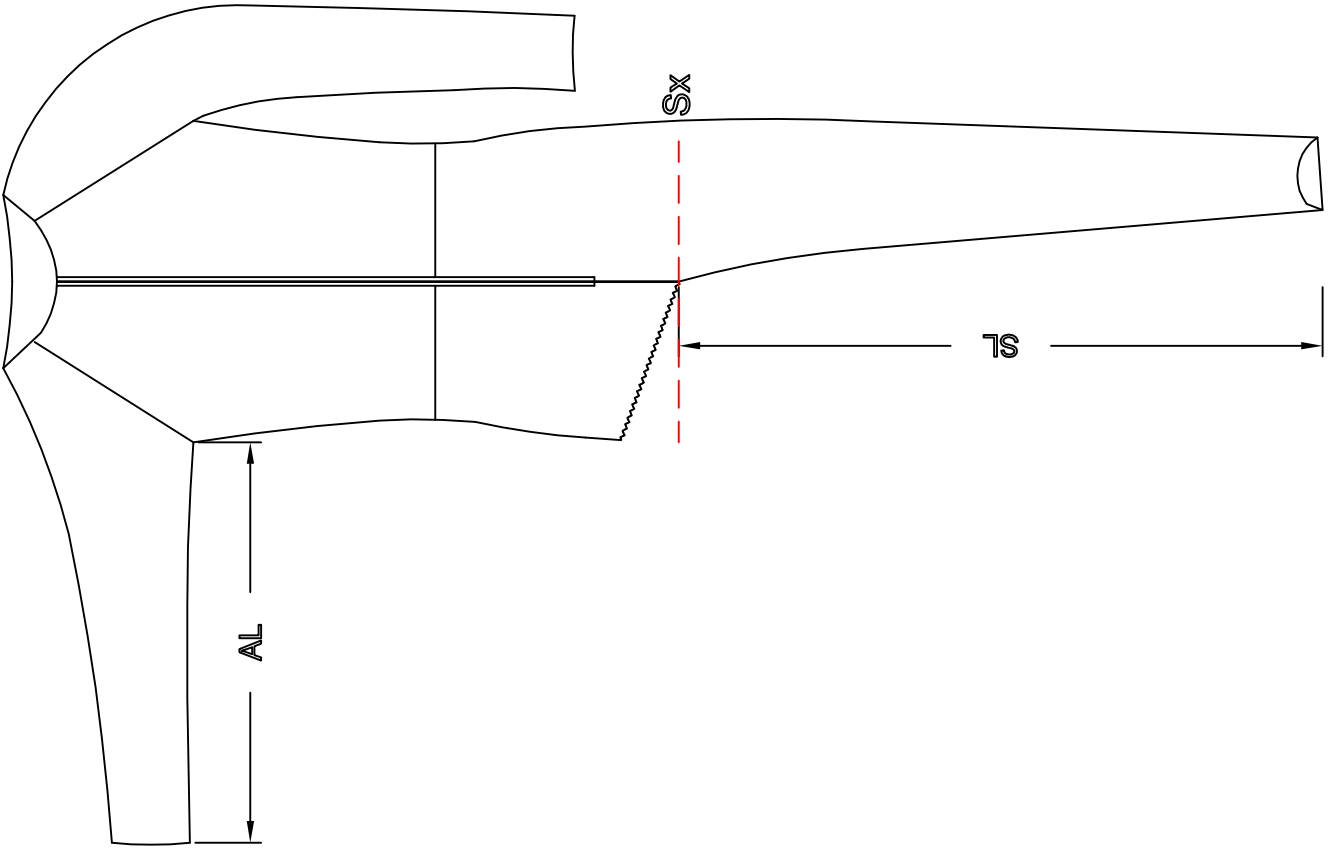

Commercial Markings on Equipment

1. General Principles

Athletes may display on their clothing or equipment a commercial marking (wording or logo) specifically permitted by the rule articles 2.1 to 2.6 per product.

All other forms of commercial markings or advertising are not permitted if they are not explicitly mentioned.

Specifications concerning the size, the form and the number of commercial markings have to be decided by the FIS Council.

FIS recognises as a manufacturer of ski equipment only those enterprises which effectively produce the ski equipment concerned.

No brand or model names which appear on hardware products (skis, poles, bindings, boots, helmet, etc.) can be shown on starting bibs or on clothing unless the name represents that of an effective producer of the clothing in question.

2. Actual specifications

2.1 *Skis, boots, bindings, ski poles, arm and leg protection, etc.*

2.1.1 Skis, ski boots, bindings, ski poles, separate arm and leg protection and other hardware in their commercially available designs are permitted and may only carry the recognised commercial markings of the effective producers.

2.1.2 The size of the commercial markings on the arm and leg protection is limited to one marking of 12 cm² on each piece.

Other sponsor markings on arm and leg protection are permitted, if those protections are part of the clothing and within the specifications of art. 2.4 (3 - 4 parts).

There is an exception for jumping skis: Please see art. 2.6.3.

A commercial marking of the effective producer on the hand protector of ski poles is permitted. The marking may be divided into two parts per single hand protector. The total surface area of the commercial markings per hand protector is limited to 15 cm².

2.1.3 Ski straps

Only hardware (skis, ski boots, bindings, ski poles) and wax suppliers are permitted to have advertising on ski straps.

No commercial advertising is permitted. Maximum 2 ski straps per pair of skis, for example one hardware and one wax supplier.

2.2 *Gloves*

A commercial marking of the effective producer on the glove is permitted. The marking may be divided into two parts per single glove. The total surface area of the commercial markings per glove is limited to 15 cm².

2.3 *Goggles*

Goggles straps shall be as on products sold to the public and may carry two commercial markings of the effective producer, not larger than 15 cm² each.

Straps shall not measure more than 4 cm in width. In case of double straps only one strap may carry the commercial markings. Lenses must be free of advertising.

Straps (without goggles) with commercial markings of goggle suppliers may not be worn.

2.4 *Clothing*

2.4.1 Articles of clothing may carry commercial markings belonging to the manufacturer and/or to other sponsors (as defined in art. 2.6)

2.4.2 The total surface area of all commercial markings on the clothing of one person shall not exceed 350 cm².

The maximum surface area for a single marking is 100 cm².

Commercial markings of the same sponsor may not appear one above the other or one beside the other.

The national association may decide on the placing of the commercial markings.

2.4.3 Roll necks may in additionally to the 350 cm² display the manufacturers trademark and/or sponsor, which may also be divided into two parts, with a maximum total surface area of 20cm². 2.4.4 A military symbol (emblem), indicating the national military organisation and similar organisations may be displayed (not on headgear or race suits), with a maximum size of 20 cm². This symbol is including within the 350 cm² total surface area of the commercial markings. This applies as well to markings of charitable organisations.

2.5 *Helmets and Headgear*

2.5.1 Helmets and headwear may carry two commercial markings of the manufacturer with a maximum size of 15 cm², one on each side, placed over the ears. The front of helmets and headwear may only be used for the emblems of national teams, and sponsors, subject to art. 2.5.2.

2.5.2 The front (in the middle) of helmets and all headwear worn in competition and within the competition area including for flower and prize-giving ceremonies, interviews etc. must carry the identification of the national ski association with a minimum size of 9 cm².

A national association may sign sponsorship contracts for helmet/headwear advertising rights of up to a maximum of 50 cm² (which may be divided between 2 identical - same size - logos) with firms who are not suppliers of ski equipment (hardware or software), subject to the regulations of each national association. In such a case, the front of helmets and headwear must carry the identification of the national ski association with a minimum size of 9 cm².

The relevant advertising must be placed either to the side of or above the identification of the national ski association. The free space between the national ski association identification in the middle of the front of the headgear and the sponsor advertising (50 cm²) must be at least 1 cm.

For headbands the relevant advertising may be placed at the front of the headband, with the identification of the national ski association to the side.

No advertising is allowed on the movable or integrated chin straps of helmets.

Additionally it is not permitted to affix a website address which refers directly to the athlete, either on headgear or other clothing.

2.6 *Other sponsors*

2.6.1 A national association may sign sponsorship contracts with firms which are not suppliers of ski equipment (hardware and software) See also ICR art. 206.

2.6.2 The dimensions of commercial markings of such sponsors must conform to the specifications in art. 2.1., art. 2.4. or art. 2.5.

2.6.3 Jumping skis: The dimensions of commercial markings of such a sponsor on jumping skis are limited to a total surface area of 160 cm² per ski. Only one commercial marking per ski is permitted, and the marking must be identical on both skis.

2.6.4 Aerial skis: The dimensions of commercial markings of such a sponsor on aerial skis are limited to a total surface of 120 cm² per ski. Only one commercial making per ski is permitted and the marking must be identical on both skis.

2.6.5 Snowboards: the base bottom of snowboards may only carry the recognized commercial markings of the effective producer. The top of snowboards may carry the commercial markings of the effective producer and up to five (5) other sponsors within a total size of 250 cm², according to the regulations of the relevant National Association.

2.7 *Accessories*

2.7.1 Fanny packs

The commercial markings belong to the NSA.

The size of commercial markings is limited to a maximum of 50 cm². The space can be used by the effective producer of the product or a commercial sponsor of the National Ski Association.

Waist bags with commercial markings may not be worn on the podium during the winners' presentation and/or the award ceremony.

2.7.2 Mobile phones with large neckband / use of drinking bottles

In order to avoid that the visibility of the starting bib sponsor during the winners' presentation and/or award ceremony is hindered, large neckbands with mobile phones and drinking bottles are prohibited on the podium.

2.8 All specifications also apply for officials, coaches, technicians, support personnel and forerunners.

II. By-laws for commercial markings and for advertising

A. Commercial markings

- A.1 Trade names, brand names and logos of other products cannot be used as model names or be shown on ski equipment, except jumping skis and freestyle aerial skis.
- A.2 The clothing or helmet shall not represent or simulate the logo or product of a manufacturer or sponsor.
- A.3 *Measuring*
- A.3.1 The size of the commercial marking is the surface area within a line that follows the actual outline of the full marking. The measuring is done in an unstretched state.
- A.3.2 If the marking is contained within an area of different colour, the total surface area of the different colour is to be measured.
- A.3.3 The accuracy of measurement of all markings will be the responsibility of the respective national association.
- A.3.4 For approval of commercial markings, it is strongly recommended to send a copy of all the commercial markings in their original size, form and colour to the FIS before use. This should be done if possible before October 1st or before the corresponding season begins in the southern hemisphere.

B. Advertising with athletes

- B.1 Advertising with athletes is allowed subject to the permission of the national association.
- B.2 Names, titles and illustrations of particular athletes can only be used in advertising with the permission of the national association.
- B.3 *Not allowed in advertising with athletes:*
- B.3.1 Any kind of advertising with alcohol, tobacco, and narcotics.
- B.3.2 The use of names, illustrations and titles of skiers for product names or product designs.
- B.3.3 Any direct statement or active product presentation.
- B.3.4 Any religious or racial discrimination

C. The above rules also apply in connection with press information or PR activities.